



**File Name:** crate kba 150 manual.pdf

**Size:** 4143 KB

**Type:** PDF, ePub, eBook

**Category:** Book

**Uploaded:** 10 May 2019, 19:17 PM

**Rating:** 4.6/5 from 627 votes.

**Status:** AVAILABLE

Last checked: 3 Minutes ago!

**In order to read or download crate kba 150 manual ebook, you need to create a FREE account.**

[\*\*Download Now!\*\*](#)

eBook includes PDF, ePub and Kindle version

[Register a free 1 month Trial Account.](#)

[Download as many books as you like \(Personal use\)](#)

[Cancel the membership at any time if not satisfied.](#)

[Join Over 80000 Happy Readers](#)

### Book Descriptions:

We have made it easy for you to find a PDF Ebooks without any digging. And by having access to our ebooks online or by storing it on your computer, you have convenient answers with crate kba 150 manual . To get started finding crate kba 150 manual , you are right to find our website which has a comprehensive collection of manuals listed.

Our library is the biggest of these that have literally hundreds of thousands of different products represented.



## Book Descriptions:

# crate kba 150 manual



It may not display this or other websites correctly. You should upgrade or use an alternative browser. Sign Up Now! I was wondering if anyone knows anything about them because i think it might need some repair but im not sure. Please help me out. ThanksWhats wrong with it. It should work OK for bass.I dont know much about that amp or amps in general, but I think the fact that its a keyboard amp, if not the main reason for your problems, plays a part.Gold Supporters see zero ads. Upgrade Now Thanks for your support! By continuing to use this site, you are consenting to our use of cookies. Everything on the amp works good except the reverb. Using my listenig device probe I get reverb singal all the way to the reverb return pot wiper to R37 68k.I lifted the down stream leg to check the resistor, resistor is good, and now with the resistor lifted I get reverb signal at that end of the resistor. When I reconnect the resistor to the board the reverb signal is gone Please have a look at the schematic and if you have any suggestions why the reverb is not working it would be very much appreciated. Thanks in advance. Punky The signal at its pin will be essentially zero. Since all the dry signals also enter this virtual ground, and apparently work, it is not clear whats wrong.I found that I can get the reverb to work if I short out R30 22 ohmresister is good to ground. Its connected to the RCA jack cable shield on the reverb tank input, also pin 6 of IC4B, and R31. The tank looks to be original 1BB2C1A 150 ohms input with a DC resistance of 26 ohms. In place of R30 22 ohm I tried a 10 ohm reverb very weak and a 1 ohm reverb was much stronger The owner bought the amp used and the reverb never worked. Why does the reverb work when I reduce R30. Thanks for your time and help. Punky I wonder if R31 somehow got stuffed BluGryBROWN instead of BluGryRED. Or some soldersplash in that area or at the jack, or cable mashed against metal, or.<http://www.hangmandigital.com/files/ford-falcon-au-workshop-manual-pdf.xml>

- **crate kba 150 manual, crate kba 150 manual, crate kba 150 manual pdf, crate kba 150 manual download, crate kba 150 manual 2017, crate kba 150 manual 2016.**

**CRATE** B-150 AMPLIFIER



We would like to take this opportunity to thank you for selecting a Crate product, and to tell you of our commitment to the design and manufacture of only the finest musical instrument amplification equipment: built for you, the musician.

You have purchased one of the most innovative sound amplification devices available today. Your Crate amplifier gives you more performance features than ever before: features that you, the musician, have asked for.

Your Crate amplifier is an American product, manufactured at our factory in St. Louis, Missouri. Only the finest available components and materials are used in the manufacture of each amplifier.

All Crate amplifiers are subject to seven or more inspection and testing steps to assure you of a high quality product. The final test for each amp is conducted by a trained musician with the instrument the amp was designed for. Any unit that does not meet the standards of his discriminating ear will not be passed.

Since all Crate products are designed, developed, and manufactured through the cooperative efforts of engineers and professional musicians, the end result is a product that responds to the musician's audio requirements, and a product that will serve your needs for years to come.

**B-150 TECHNICAL SPECIFICATIONS**

<b>Output Power Rating</b>	150 watts RMS @ 5% THD 4 ohm load - 120 VAC line
<b>Speaker Size and Rating</b>	B-150C: 15" with 2-1/2" voice coil and 56 oz. magnet Power Handling 150 watts B-150CS: 18" Electro-Voice Force B-150H: No speaker, head only
<b>Equalization</b>	-12 dB @ 50, 100, 200, 400, 800, and 1600 Hz
<b>Presence Control</b>	12 dB boost @ 3KHz
<b>Contour Switch</b>	Special frequency tailoring
<b>Input Impedance</b>	220 K ohms/ 0 dB input 56 K ohms/ -15 dB input
<b>Maximum Input Signal Level Accepted</b>	15 volts, peak to peak
<b>Gain @ 1 KHz</b>	57 dB with tones flat. Presence and Contour off
	<b>Outputs @ Full Power</b>
Unbalanced Line Out (rear panel)	.85 volts RMS
Balanced Line Out (600 ohm load)	.98 volts RMS
Effects Send ("Pre")	.52 volts RMS
BI-amp Outputs	.65 volts RMS
Line Out (bottom panel)	.65 volts RMS
<b>Signal to Noise Ratio</b>	65 dB
<b>Input Power Requirements</b>	120 VAC, 60 Hz 500 watts max
<b>Cabinet Size and Weight</b>	23" H x 24" W x 16" D 70 lbs.

**CAUTION:** To reduce the risk of electric shock, do not remove chassis. No user serviceable parts inside. Refer servicing to qualified service personnel. To reduce the risk of fire or electric shock, do not expose this appliance to rain or moisture.  
Specifications subject to change without notice.

What is in there is a 560 ohm green, blue, brown. Ohm meter test confirmed that. Maybe Crate screwed up the schematic too. I have found some other resistors in another part of the amp to be off from what is on the schematic but not by much. 20%. I will tack in a 6.8k in R31 and the 22 ohm in R30 tomorrow and see what happens What about snot or short on the tank input wire, connector, whatever I did replace IC1A with no change. All resistors and caps connected to IC1A tested good. Is the difference between the dry signal input and the wet output signal normal. A bit less with 150r input, but still 1001 loss. VERY variable with frequency. This might really be better with a controllable signal generator and an audio milliVolt meter. You want a few midrange frequencies the tank response is very peaky and controllable down to 10mV. However a chip failure is VERY unlikely. Bad joints and contacts outnumber bad chips manytoone. Plus I got a strong probe signal there. How does the signal flow work on these amps. I do have an antique Korg WT10A guitar tuner that will produce sound through its output jack in three octives and I can vary the pitch between 430 to 460Hz. Can I use that as a signal generator. PRR thank you again for your time and help with this project. September SaleSeptember SaleIt has gain, level, 3band EQ, headphone jack, RCA inputs, effects loop, DI, and left, right, and mono speaker outputs. It also comes with a padded travel bag and a universal power supply. Please check the fields highlighted in red. Currency. The VME section features 8 slots suitable for 6Ux160mm boards, with VME64 compliant backplane. The section is powered by universal AC input Power Supply. The NIM section consists of 7 NIM slots 5 free provided with pluggable 150W power supply. The Unit is powered by 220 Vac or 115 Vac, 50 60 Hz. <http://www.dianacb.cz/userfiles/ford-falcon-ba-ute-owners-manual.xml>



In no event will the authors, partners or contributors be held liable for any damages, claims or other liabilities direct or indirect, arising from the use of this CAEN SwFw or any derivative work. This CAEN SwFw Licence defines legal use of the CAEN SwFw, all updates, revisions, substitutions, and any copies of the CAEN SwFw made by or for you. All rights not expressly granted to you are reserved by C.A.E.N. or their respective owners. Your licence to the CAEN SwFw under this CAEN SwFw Licence continues until it is terminated by either party. You may terminate the CAEN SwFw Licence by discontinuing use of all or any of the CAEN SwFw and by destroying all your copies of the applicable CAEN SwFw. You understand that the CAEN SwFw is not designed for such purposes and that its failure in such cases could lead to death, personal injury, or severe property or environmental damage for which C.A.E.N. is not responsible. You agree to abide by all applicable proprietary rights laws and other laws. C.A.E.N. owns all rights, title, and interest in and to their applicable contributions to the CAEN SwFw. This CAEN SwFw Licence grants you no right, title, or interest in any intellectual property owned or licensed by C.A.E.N., including but not limited to the CAEN SwFw and the C.A.E.N. trademarks, and creates no relationship between you and C.A.E.N. other than that of C.A.E.N. to licensee. You agree not to assign, copy, transfer, or transmit CAEN SwFw. Your licence to use the CAEN SwFw will terminate if you violate these restrictions. If your licence terminates, you agree to cease any and all use of the CAEN SwFw. All rights in any thirdparty data, any thirdparty CAEN SwFw, and any thirdparty data servers, including all ownership rights are reserved and remain with the respective third parties. You agree that these third parties may enforce their rights under this Agreement against you directly in their own name. They are Provided "as is.

" Some jurisdictions do not allow restrictions on implied warranties so some of these limitations may not apply to you. Damages excluded by this clause include, without limitation, those for loss of business profits, injury to person or property, business interruption, loss of business or personal information. Some jurisdictions do not allow limitation of incidental or consequential damages so this restriction may not apply to you. You agree to indemnify and hold the C.A.E.N. Entities harmless from any claim or demand, including reasonable legal fees, made by any third party in connection with or arising out of your use of the CAEN SwFw, your violation of any terms or conditions of this CAEN SwFw Licence, your violation of applicable laws, or your violation of any rights of another person or entity. This Agreement shall be construed and governed by Italian Law. The United Nations Convention on the International Sale of Goods does not apply to this CAEN SwFw Licence. Any dispute arising out of or in connection with this Agreement shall be referred to and finally resolved by Arbitration under the provisions of Italian Law c.p.c. art 816 and following. by one Arbitrator. The Arbitrator shall be nominated from Chairman of the Court of Milan. The place of Arbitration shall be Milan, Italy and the language shall be English. Download By closing this banner or continuing the navigation, you accept the use of cookies. If you want to know more or optout of some cookies see our cookies policy. Contact your nearest Simpro agent for pricing and availability. Customers within New Zealand may be able to buy this product online through the Simpro Shop.

With a single movement of the tiller, the Crate Genie 's lifting arms clamp against a stack of crates and raise it clear of the ground. Once raised, the Crate Genie can be moved and steered effortlessly. Like all Simpro products, it is designed to be maintenancefree and exceptionally reliable.

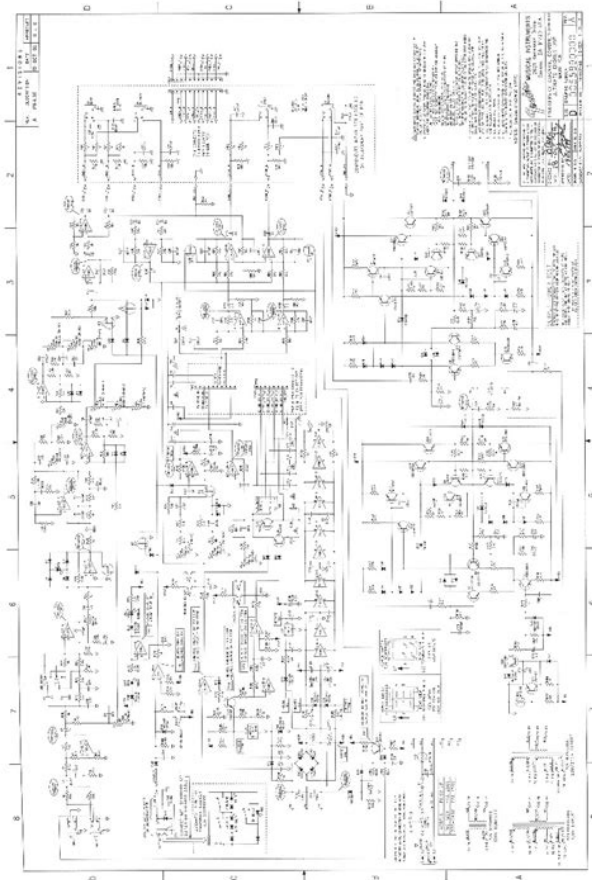

It is very versatile, and suits most use cases with no modification. We will get back to you in 24 hours. Thank you. Close Feedback Found a bug. Suggestions Copyright Need help. Business Development General inquiry Email address optional A message is required Message required. The number of crates to be cleaned is allimportant when making this choice. The standard format of this Euronorm crate is 600x400x200 millimeter. Within the Eseries crates with other heights are also available The E1 crate 125 millimetres high and the E3 crate 300 millimetres high. Because of its large volume 60 litres this last type is less practical and therefore also less popular. Therefore they are very hygienic in their use, simple to clean and dry quickly. The crates can be fed in widthways into a standard crate washer that has a track width of 600 millimetres. Then it would be wise to consider an automated process. You can determine whether this is profitable by comparing the investment costs for this process to the labour costs for a manual process. Do you have cheap labour. An automatic process will then be a less interesting investment. Whether that is the choice depends mainly on the companys philosophy. The key question then is What part does automation play within the management of the business For example, at many companies the load carriers are brought in manually and only the process after washing is automated. Via a conveyor belt and with a stacker the clean crates are then automatically stacked onto a pallet. To also automate the process that takes place before the crates go into the washer, a destacker is needed that removes the crates from the pallet. Via a conveyor belt the crates are then transported to the washer. Depending on the route that the crates must follow, automatic tippers can also be added to the logistics process.

<http://cydistribution.com/images/commodore-sx-64-manual.pdf>



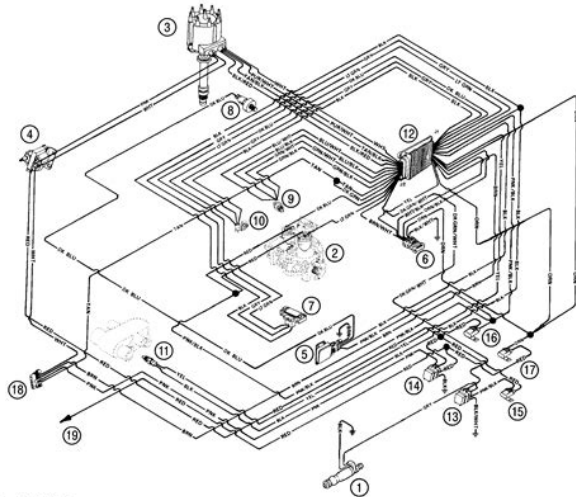

- 1 - Fuel Pump
- 2 - Throttle Body
- 3 - Distributor
- 4 - Coil
- 5 - Electronic Spark Control (KS) Module
- 6 - Data Link Connector (DLC)
- 7 - Manifold Absolute Pressure (MAP) Sensor
- 8 - Knock Sensor
- 9 - Idle Air Control (IAC)
- 10 - Throttle Position (TP) Sensor
- 11 - Engine Coolant Temperature (ECT) Sensor
- 12 - Electronic Control Module (ECM)
- 13 - Fuel Pump Relay
- 14 - Ignition/System Relay
- 15 - Fuse (15 Amp) Fuel Pump
- 16 - Fuse (15 Amp) ECM/DLC/Battery
- 17 - Fuse (10 Amp) ECM/Injector/Ignition/Knock Module
- 18 - Harness Connector To Starting/Charging Harness
- 19 - Positive (+) Power Wire To Engine Circuit Breaker

Naturally the place where the crate washer is going to be placed within the company building must be carefully considered, so that the logistics process runs as efficiently as possible. Would you like to know, quickly and simply, which crate washer suits your company best. Then please fill in the crate washer calculator and you will receive made to measure advise. Vyberajte z 2 700 inzeratov. Predajte lahko a rychlo na Bazos.sk. Cez 400 tisíc uzivatelov za den. Najdite co potrebujete vo Vasej kategorii strana 83. Find and download user guides and product manuals. COUSTIC CRANE CRATE CRATE AMPLIFIERS CRAYON AUDIO CREDA 60 Amplifier Head. Keyboard arm. VISKBFP. Keyboard and flat panel monitor arm kit. Vyberajte z 2 700 inzeratov. Najdite co potrebujete vo Vasej kategorii strana 83. Automotive vehicle designed for the carriage of frozen cargo. 60 CO. Carboy, nonprotected. CP. Carboy, protected. CQ. Cartridge. CR. Crate. CS KB kilocharacter. Zepf 2404837 Plastic bottle crate with a truss for holding bottles. Schoeller. Hope everyone is well. Its three channels and has 4 EQ. I understand these are keyboard amps but are used for basses and sometimes PAs. It sound pretty good with a mic plugged into it too. Any help input would help. Thanks. And I think you snagged what I need! Used to have a similar Peavey KB100 60 watt with 15 inch and tweeter. Does yours have a 15 Looks like you got a good deal. Keyboard amps are broadrange amps so work with a lot of instruments. Im fairly new myself, and getting to know everyone. Spent most of my time on the Recording Forum up to now. I didnt take off the tweed but it does have what looks like a 4 inch horn above the 15. It has two vent holes on the bottom corners. Its a little flat for bass though. To me it seems to not have enough treble even with the highs pumped up and the lows knocked down. I got a real singer on the mic and I was very impressed with the quality for vocals. Id love to get ahold of one!

<http://d-frax.com/images/commodore-sewing-machine-manual.pdf>



Its an amp, right What kind of help are you seeking Its an amp, right What kind of help are you seeking Versatility, any known problems, how they sound as a small monitor or plugged into one, When was it made, I could go on but Im sure you must now understand. Sorry if I didnt make myself clear enough on my first post, mate. I just got ahold of one of these today and it sounds amazing, perfect for anything really.I dont have one so I cant really try it out. Mines in about pristine condition, it gets some crackling when turning up the master, but other than that, everything works.I think its from the late 80s or early 90s, cause it seems a little weathered, and anything that was white on it, such as the tolex, is tinted a bit. Paste as plain text instead Display as a link instead Clear editor Upload or insert images from URL.

<http://www.thebetterinsurance.com/wp-content/plugins/formcraft/file-upload/server/content/files/16287a6bd1f74e---Calculus-single-variable-5th-edition-solutions-manual-pdf.pdf>